

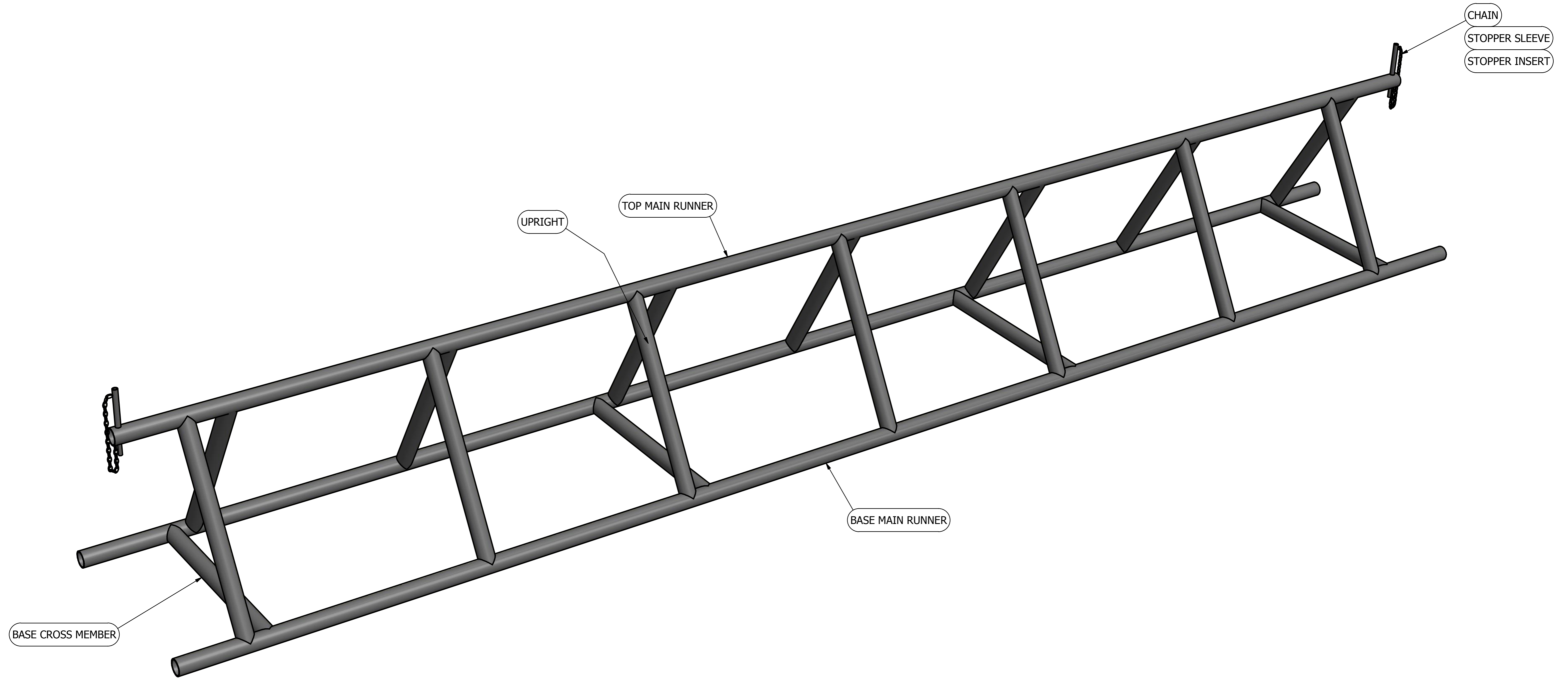

NOTES:
-THE FULL PIPE RACK SAFE UNIFORM LOADING IS 1600 LBS/FT.
-ALL WELDS CONTINUOUS FILLETS.
-ALL WELDING SHALL CONFORM TO CWB CERTIFIED CSA W47.1.

| 28' PIPE RACK PARTS LIST | | | | |
|--------------------------|-----|------------------------------|----------|----------------|
| PART NUMBER | QTY | DESCRIPTION | MATERIAL | MASS |
| BASE MAIN RUNNER | 2 | PIPE Ø3 SCH 40 X 336 | SA106-B | 212.620 lbmass |
| BASE CROSS MEMBER | 4 | PIPE Ø3 SCH 40 X 44-1/2 | SA106-B | 26.591 lbmass |
| TOP MAIN RUNNER | 1 | PIPE Ø3 SCH 40 X 336 | SA106-B | 212.471 lbmass |
| UPRIGHT | 14 | PIPE Ø3 SCH 40 X 44-1/2 | SA106-B | 26.566 lbmass |
| STOPPER INSERT | 2 | R BAR Ø3/4 X 14 | C1020 | 1.756 lbmass |
| STOPPER SLEEVE | 2 | PIPE Ø3/4 STD X 8 | SA106-B | 0.756 lbmass |
| CHAIN | 2 | 3/16 CHAIN REGULAR LINK X 24 | GR30 | 0.583 lbmass |



ISOMERIC VIEW OF 28' PIPE RACK

| | | | | |
|---------------|------------|--|--|-----|
| DRAWN JWL | 11/14/2014 |  ROCK TUBULARS | 28' PIPE RACK PIPE RACK DETAILS | |
| CHECKED MT | | | | |
| QA | | 28 FT PIPE RACK-01 | | |
| MFG | | | | |
| APPROVED | | SIZE | DWG NO | REV |
| | | | 28 FT PIPE RACK-01 | |
| | | SCALE | SHEET 1 OF 1 | |

4

3

2

1

28' PIPE RACK PARTS LIST

| PART NUMBER | QTY | DESCRIPTION | MATERIAL | MASS |
|-------------------|-----|------------------------------|----------|----------------|
| BASE MAIN RUNNER | 2 | PIPE Ø3 SCH 40 X 336 | SA106-B | 212.620 lbmass |
| BASE CROSS MEMBER | 4 | PIPE Ø3 SCH 40 X 44-1/2 | SA106-B | 26.591 lbmass |
| TOP MAIN RUNNER | 1 | PIPE Ø3 SCH 40 X 336 | SA106-B | 212.471 lbmass |
| UPRIGHT | 14 | PIPE Ø3 SCH 40 X 44-1/2 | SA106-B | 26.566 lbmass |
| STOPPER INSERT | 2 | R BAR Ø3/4 X 14 | C1020 | 1.756 lbmass |
| STOPPER SLEEVE | 2 | PIPE Ø3/4 STD X 8 | SA106-B | 0.756 lbmass |
| CHAIN | 2 | 3/16 CHAIN REGULAR LINK X 24 | GR30 | 0.583 lbmass |

NOTES:
-THE FULL PIPE RACK SAFE UNIFORM LOADING IS 1600 LBS/FT.
-ALL WELDS CONTINUOUS FILLETS.
-ALL WELDING SHALL CONFORM TO CWB CERTIFIED CSA W47.1.

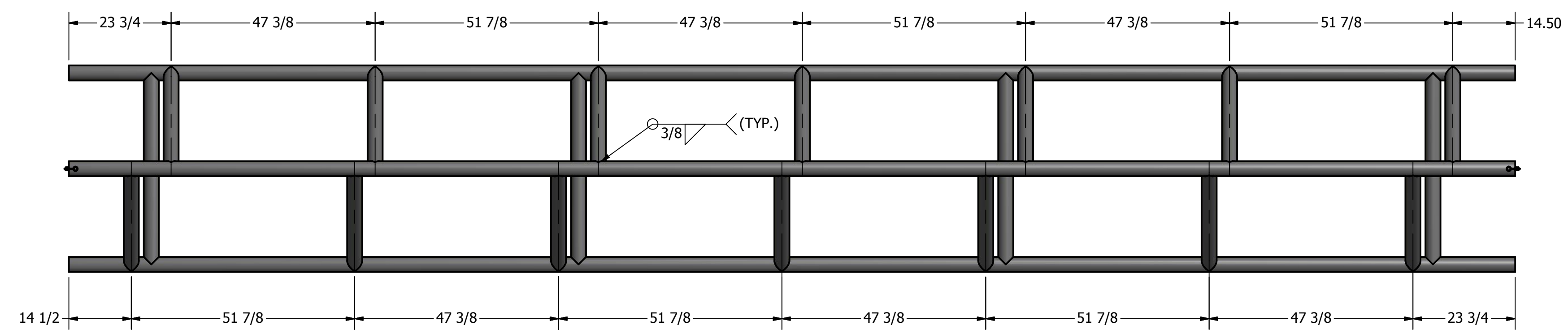

VIEW A-A

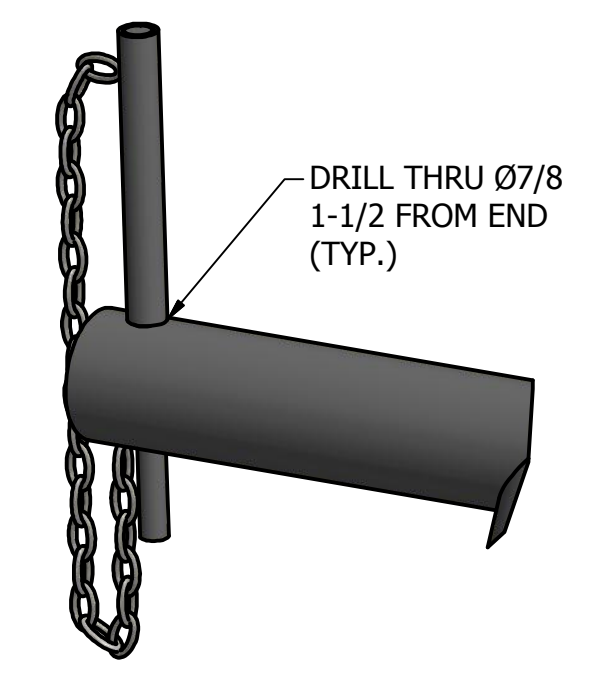

DETAIL A

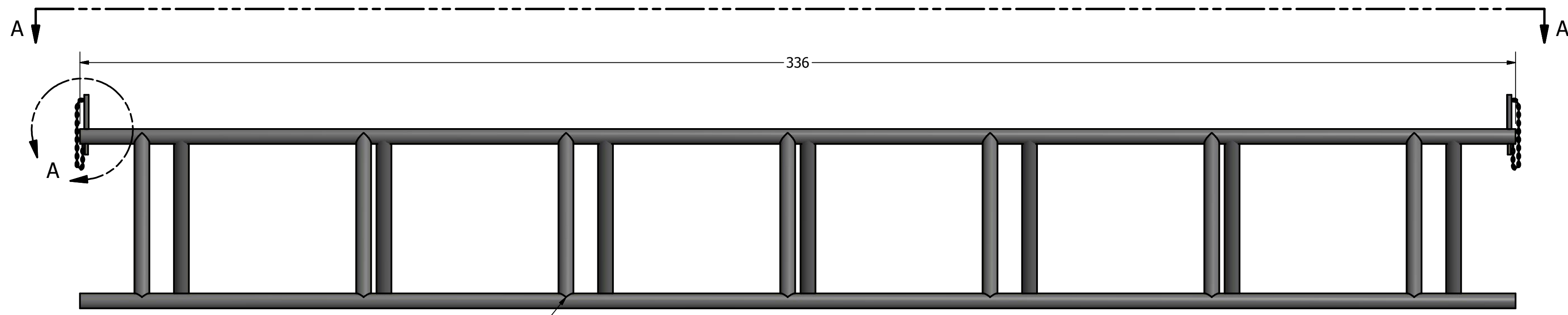

SIDE VIEW

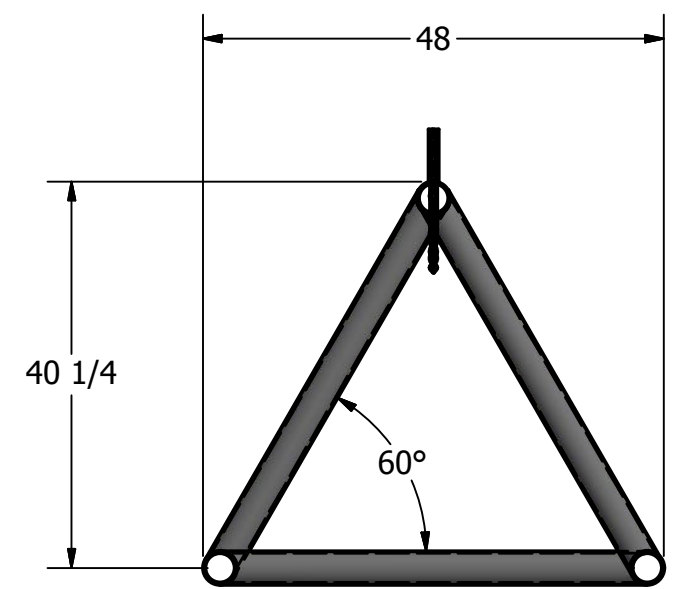

VIEW B-B

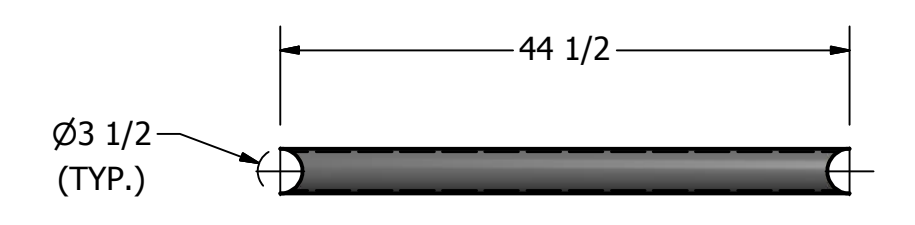

DETAIL OF BASE CROSS MEMBER

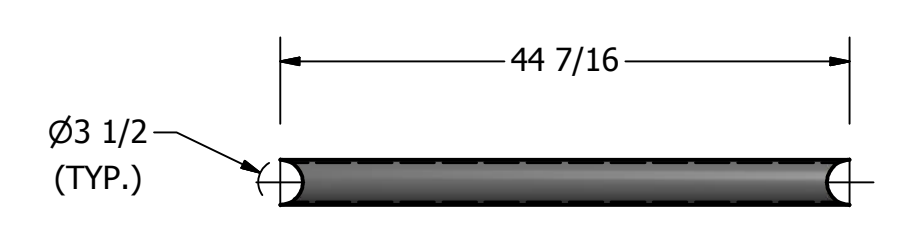

DETAIL OF UPRIGHT

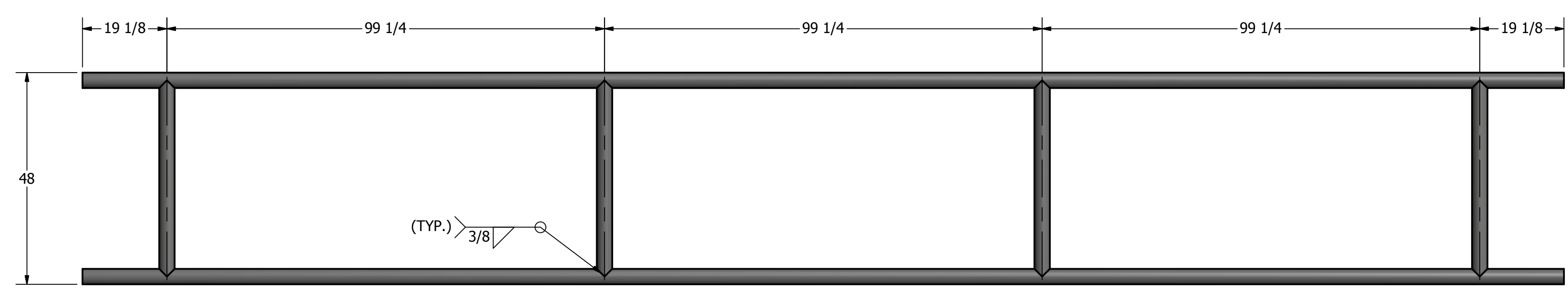

DETAIL OF BASE

| | | | | |
|----------|-----|------------|---|--------------|
| DRAWN | JWL | 11/14/2014 | ROCK TUBULARS | |
| CHECKED | MT | QA | | |
| MFG | | | 28' PIPE RACK PIPE RACK DETAILS | |
| APPROVED | | | | |
| | | | | |
| | | SIZE | DWG NO | REV |
| | | | 28 FT PIPE RACK-02 | |
| | | SCALE | | SHEET 1 OF 1 |

4

3

2

1